

## BACnet® communication module for TCX2: AEX-BAC



AEX-BAC

### Features

- BACnet® MS/TP communication over RS485
- Slave type of communication
- Supports up to 127 nodes on one network
- Galvanic isolated bus connection
- Baudrates: 4800 / 9600 / 19200 / 38400 / 57600 / 76800
- LED indicators

### TCX2-BAC Protocol Implementation Conformance Statement (PICS)

Vendor Name: Vector Controls

Product Name: TCX2 Controls series

TCX2 product description:

The TCX2 communicating BACnet® controllers are designed as universal controls equipment suitable for a large number of applications. They may be used in zoning and other applications which are monitored by a BACnet® MS/TP network.

### Supported BACnet® Interoperability Blocks (BIBB)

The BACnet® interface conforms to the B-ASC device profile (BACnet® Application specific controller). The following BACnet® Interoperability Building Blocks (BIBB) are supported.

BIBB	Type	Name
DS-RP-B	Data sharing	Read property - B
DS-RPM-B	Data sharing	Read property multiple - B
DS-WP-B	Data sharing	Write property - B
DM-DCC-B	Device management	Device communication Control - B
DM-DDB-B	Device management	Dynamic device binding - B
DM-DOB-B	Device management	Dynamic object binding - B
DM-TS-B	Device management	Time synchronisation - B

### Supported standard BACnet® application services

- ReadProperty
- ReadPropertyMultiple
- WriteProperty
- DeviceCommunication
- I-Am
- I-Have
- TimeSynchronisation

### Supported standard Object types

- Device
- Analog input
- Analog value
- Binary input
- Binary value
- Multi-state Value

### LED indicators

The BACnet® interface features a green LED and a red LED for indication of traffic on the RS-485 bus. The green LED is lit when an incoming packet is received, and the red LED is lit when an outgoing packet is transmitted to the bus. At power-up, both LED blink twice simultaneously as a sign of the boot process being completed. A constantly lit LED serves as an indication of a fault condition in the reception or sending process.

## Technical specifications

**Notice!** Failure to follow specifications and local regulations may cause equipment damage. Misapplication will void warranty.

<b>Power Supply</b>	Power Requirements	5VDC ±5%
	Power Consumption	Max. 2VA
<b>Network</b>	Hardware interface	RS485 in accordance with EIA/TIA 485
	Max nodes per network	128
	Max nodes per segment	64 (Vector devices only)
	Cabling	Twisted Shielded Pair (TSP) cable category 5 or 6.
	Impedance	balanced 120 ohm
	Nominal Capacitance	100 pF/m 16pF/ft or lower
	Nominal Velocity	65% or higher
	Galvanic Isolation	The communication circuitry is galvanic isolated
	Line termination	A line termination resistance (120 ohm) shall be connected between the terminals - (TX2) and + (TX3) of the furthestmost node of the network
	Line polarization	The device needs polarization
<b>BACnet®</b>	Communication standard	BACnet® MS/TP Master on RS485
	Default setting	9600 Baud rate
	Communication speed	9600, 19200, 38400, 57600, 76800
	Environment	
<b>Environment</b>	Operation	To IEC 721-3-3
	Climatic Conditions	class 3 K5
	Temperature	0...50 °C (32...122 °F)
	Humidity	<95 % r.H. non-condensing
	Transport & Storage	To IEC 721-3-2 and IEC 721-3-1
	Climatic Conditions	class 3 K3 and class 1 K3
Temperature	-25...70 °C (-13...158 °F)	
Humidity	<95 % r.H. non-condensing	
Mechanical Conditions	class 2M2	
<b>Standards</b>	conformity	
	EMC Directive	2004/108/EC
	Low Voltage Directive	2006/95/EC
	Product standards	
	Automatic electrical controls for household and similar use	EN 60 730 -1
	Special requirement on temperature dependent controls	EN 60 730 - 2 - 9
	Electromagnetic compatibility for industrial and domestic sector	Emissions: EN 60 730-1 Immunity: EN 60 730-1

### Bus connection

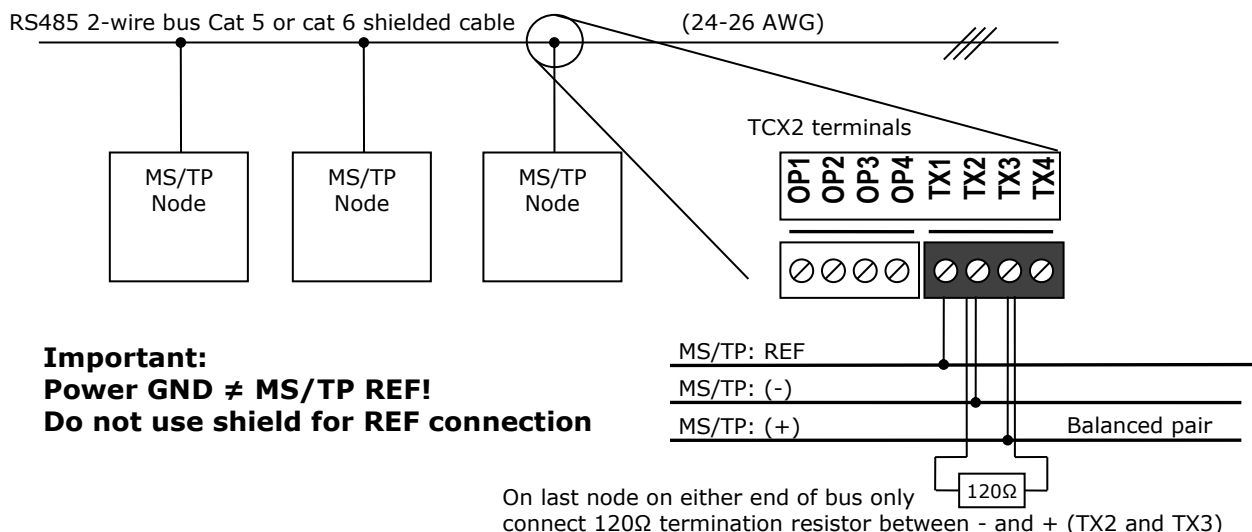

**Line polarization:**

The device needs line polarization. 550Ω per wire, maximum 2 sets per segment

**Shield connection:**

The shield of the wire must not be used to connect to the REF terminal. Connect all the shields together and ground in one single point on the network. Make sure the shields do not accidentally touch the ground. Multiple ground connections induce noise and affect communication

## Configuration of AEX-BAC

The communication parameters may be set via TCX2-OP controllers or OPA2 terminals once the device is plugged in the TCX2 base. Login to the controller as follows:

1. Press UP/DOWN buttons simultaneously for three seconds. The display will show firmware version and revision number. Press the OPTION button to start login.
2. CODE is shown in small display.
3. Select 241 using UP/DOWN buttons.
4. Press OPTION after selecting the correct code.
5. Once logged in with 241 control modules are displayed (Lp1, Lp2, 1u, 2u, etc.) – select with UP/DOWN the communication parameters **CO** and open with OPTION. As soon as the module is open its parameters are displayed.
6. Select the parameters with the UP/DOWN buttons. Change a parameter by pressing the OPTION button. Three arrows are displayed to indicate that the parameter may be modified. Use UP/DOWN buttons to adjust the value.
7. After you are done, press OPTION to save the new value and return to the selection level (arrows disappear when selection is saved). Pressing left hand POWER button without pressing OPTION will discard the value and return without saving. For control parameters press POWER again to leave parameter selection and return to control module selection.

Press the POWER to leave the menu. The unit will return to normal operation if no button is pressed for more than 5 minutes.

### COM parameters

Parameter	Description	Range	Default
CO 00	Bus plug-in id (read only)	0...255	-
CO 01	Bus plug-in software version (read only)	0...255	-
CO 02	Bus plug-in software revision ( read only)	0...255	-
CO 03	Communication address (must be unique in network)	0...127	0
CO 04	Baud rate: 0 = <b>9600</b> 1 = 19200 2 = 38400 3 = 57600 4 = 76800 5 = 115200	0...5	0 (9600)
CO 05	Highest master	0...255	127
CO 06	Device object ID1 000000xx	0...99	03
CO 07	Device object ID2 0000xx00	0...99	43
CO 08	Device object ID3 00xx0000	0...99	19
CO 09	Device object ID4 xx000000	0...4	4
CO 10	Send I-am at boot	ON, OFF	OFF

## Object list

### Device Object

Property	Description	Range/Type	R/W
Object_Identifier	Device object identifier	22 bit	R/W
Object_Name	Name of device	32 Bytes	R/W
System_Status	Current physical and logical status: - <b>OPERATIONAL</b> - OPERATIONAL_READ_ONLY - <b>DOWNLOAD_REQUIRED</b> - DOWNLOAD_IN_PROGRESS - <b>NON_OPERATIONAL</b> - BACKUP_IN_PROGRESS		
Vendor_Name	Vector Controls	String	R
Vendor_Identifier	5xx		R
Model_Name	TCX2-40863-BAC (assembled by firmware)	String	R
Firmware_Revision	BACnet Firmware Revision	String	R
Application_Software_Revision	Controller Firmware Version (assembled by firmware)	String	R
Description	Description of controller or location	32 Bytes	R/W
Local_Time	Time of controller in 3 Bytes HH:MM:SS	HH:MM:SS	R
UTC_Offset	Offset to UTC time in case UTC time synchronization is used	-780..780	R/W
Max_Master	Number of the highest addressed node	1..127	R/W
Database_Revision	Increases if the settings change	2 Bytes	R
Protocoll_Object_Types_Supported	List of object types supported	List	R
Object_List	List of all objects currently implemented in the device	List	R

### Analog Input Object

Property	Description / Property description	Range/Type	R/W
Object_Identifier	AI number	8bit	R
Object_Name	Name of the input, Assembled from template plus number		R
Description	Description of the input	16 Bytes	R/W
Preset_Value	Current value of input, writable only if out of service is set	Floating Point	R/W
Status_Flags	In_Alarm, Fault, Overridden, Out_Of_Service	Flags	R
Event_State	Always NORMAL	Flags	R
Reliability	NO_FAULT_DETECTED, NO_SENSOR, OVER_RANGE, UNDER_RANGE, OPEN_LOOP, SHORTED_LOOP, COMMUNICATION_FAILURE, UNRELIABLE_OTHER	List	R
Out_Of_Service	If set, the value is not updated by the physical input and can be written via Bacnet. Actual input of controller is not affected.	Flag	R/W
Units	Describes the units used. Degree Celsius & Fahrenheit has to be set by MV02.	Coded Value	R/W

### Analog Value Object

Property	Description / Property description	Range/Type	R/W
Object_Identifier	AV number	8bit	R
Object_Name	Name of the value, Assembled from template plus number		R
Description	Description of the input	16 Bytes	R/W
Preset_Value	Current value of input, writable only if out of service is set	Floating Point	R/W
Status_Flags	In_Alarm, Fault, Overridden, Out_Of_Service	Flags	R
Event_State	Always NORMAL	Flags	R
Out_Of_Service	If set, the value is not updated by the controller and can be written via Bacnet. Actual output of controller is not affected.	Flag	R/W
Units	Describes the units used. Degree Celsius & Fahrenheit has to be set by MV02.	Coded Value	R/W

### Binary Input Object

Property	Description / Property description	Range/Type	R/W
Object_Identifier	BI number	8bit	R
Object_Name	Name of the input, Assembled from template plus number		R
Description	Description of the input	16 Bytes	R/W
Preset_Value	True or False, writable only if out of service is set	ON, OFF	R/W
Status_Flags	In_Alarm, Fault, Overridden, Out_Of_Service	Flags	R
Event_State	Always NORMAL	Flags	R
Reliability	NO_FAULT_DETECTED, NO_SENSOR, OVER_RANGE, UNDER_RANGE, OPEN_LOOP, SHORTED_LOOP, COMMUNICATION_FAILURE, UNRELIABLE_OTHER	List	R
Out_Of_Service	If set, the value is not updated by the physical input and can be written via Bacnet. Actual input of controller is not affected.	Flag	R/W
Polarity	NORMAL or REVERSE	List	R/W
Inactive_Text	Contains text to be shown if inactive	x Bytes	R/W
Active_Text	Contains text to be shown if active	X Bytes	R/W

### Binary Value Object

Property	Description / Property description	Range/Type	R/W
Object_Identifier	BV number	8bit	R
Object_Name	Name of the input, Assembled from template plus number		R
Description	Description of the input	16 Bytes	R/W
Preset_Value	True or False, writable only if out of service is set	ON, OFF	R/W
Status_Flags	In_Alarm, Fault, Overridden, Out_Of_Service	Flags	R
Event_State	Always NORMAL	Flags	R
Out_Of_Service	If set, the value is not updated by the physical input and can be written via Bacnet. Actual input of controller is not affected.	Flag	R/W
Polarity	NORMAL or REVERSE	List	R/W
Inactive_Text	Contains text to be shown if inactive	x Bytes	R/W
Active_Text	Contains text to be shown if active	X Bytes	R/W

### Multi State Value Object

Property	Description / Property description	Range/Type	R/W
Object_Identifier	MV number	8bit	R
Object_Name	Name of the input, Assembled from template plus number		R
Description	Description of the input	16 Bytes	R/W
Preset_Value	Unsigned Integer	8bit	R/W
Status_Flags	In_Alarm, Fault, Overridden, Out_Of_Service	Flags	R
Event_State	Always NORMAL	Flags	R
Out_Of_Service	If set, the value is not updated by the physical input and can be written via Bacnet. Actual input of controller is not affected.	Flag	R/W
Number_Of_States	Unsigned Integer	8bit	R/W
State_Text	Array of strings	16x8bytes max	R

## Description of available objects

### Controller Information

Object	Name (8 Bytes)	Description	Range/Type	R/W
AV 00	#CtrLp	Number of control loops	8bit	R
AV 01	#BinIn	Number of binary inputs	8bit	R
AV 02	#uIn	Number of universal inputs	8bit	R
AV 03	#vIn	Number of virtual inputs	8bit	R
AV 04	#BinOut	Number of binary outputs	8bit	R
AV 05	#aOut	Number of analog outputs	8bit	R
AV 06	#Fan	Number of fan outputs	8bit	R
AV 07	#FLOut	Number of floating outputs	8bit	R
AV 08	#Alarm	Number of alarms	8bit	R
AV 09	#AuxFun	Number of auxiliary functions	8bit	R
AV 10	#Sched	Number of time schedules	8bit	R
AV 11	#PerSchd	Number of switching times / time schedule	8bit	R

### Controller State

Object	Name (8 Bytes)	Description / Property description	Range/Type	R/W
BV 00	OpStOo	Operation state On - Off: Inactive / Active	BV	R/W
MV 00	OpStCoSt	Operation state Comfort - Standby: 1 = Comfort, 2 = Standby	MV	R/W
MV 01	OpStHeCo	Operation state Heat - Cool: 1 = Heat, 2 = Cool,	MV	R/W
MV 02	Degree	Operation state Celsius - Fahrenheit: 1 = Celsius, 2 = Fahrenheit	MV	R/W
BV 01	FanOnly	Operation state Fan Only: Not implemented in this version	BV	R/W
BV 02	Schedule	Operation state Time Schedules: Inactive / Active	BV	R/W
BV 03	AccOpMod	Enable access to operation modes	BV	R/W
BV 04	AccSp	Enable access to set points	BV	R/W
BV 05	AccMan	Enable manual control in cascade and for fan speeds	BV	R/W
BV 06	AccHeCo	Enable change of heating/cooling mode for 2 pipe systems	BV	R/W
BV 07	AccSchd	Enable access to time programs:	BV	R/W

### Universal Inputs

Object	Name (8 Bytes)	Description	Description	R/W
AI 101	UI-01	Universal Input 01	16bytes	R
AV 101	UI-01-OS	Universal Input 01 Offset (calibration = 01u6)	16bytes	R/W
AI 102	UI-02	Universal Input 02	16bytes	R
AV 102	UI-02-OS	Universal Input 02 Offset	16bytes	R/W
AI 103	UI-03	Universal Input 03	16bytes	R
AV 103	UI-03-OS	Universal Input 03 Offset	16bytes	R/W
AI 104	UI-04	Universal Input 04	16bytes	R
AV 104	UI-04-OS	Universal Input 04 Offset	16bytes	R/W
AI 105	UI-05	Universal Input 05	16bytes	R
AV 105	UI-05-OS	Universal Input 05 Offset	16bytes	R/W
AI 106	UI-06	Universal Input 06	16bytes	R
AV 106	UI-06-OS	Universal Input 06 Offset	16bytes	R/W
AI 107	UI-07	Universal Input 07	16bytes	R
AV 107	UI-07-OS	Universal Input 07 Offset	16bytes	R/W
AI 108	UI-08	Universal Input 08	16bytes	R
AV 108	UI-08-OS	Universal Input 08 Offset	16bytes	R/W
AI 109	VI-01	Virtual Input 01	16bytes	R/W
AV 109	VI-01-OS	Virtual Input 01 Offset	16bytes	R/W
AI 110	VI-02	Virtual Input 02	16bytes	R/W
AV 110	VI-01-OS	Virtual Input 02 Offset	16bytes	R/W

### Alarms

Object	Name	Description	Description	R/W
MV 601	AL-01	Alarm 1: Not Active, Active, Need confirmation	16 bytes	R/W*
MV 602	AL-02	Alarm 2: Not Active, Active, Need confirmation	16 bytes	R/W*
MV 603	AL-03	Alarm 3: Not Active, Active, Need confirmation	16 bytes	R/W*
MV 604	AL-04	Alarm 4: Not Active, Active, Need confirmation	16 bytes	R/W*
MV 605	AL-05	Alarm 5: Not Active, Active, Need confirmation	16 bytes	R/W*
MV 606	AL-06	Alarm 6: Not Active, Active, Need confirmation	16 bytes	R/W*
MV 607	AL-07	Alarm 7: Not Active, Active, Need confirmation	16 bytes	R/W*
MV 608	AL-08	Alarm 8: Not Active, Active, Need confirmation	16 bytes	R/W*

\*) Writable to "not active" only, if state is "not active, need confirmation";

### Control Loops

Object	Name	Description	Description	R/W
MV 211	LP-01-ST	State of control loop: Disabled, Heating, Cooling		R
AV 211	LP-01-SSP	Saved setpoint	16bytes	R/W
AV 212	LP-01-CSP	Calculated setpoint		R
AV 213	LP-01-PROP	Proportional output		R
MV 212	LP-01-DO	Binary output: Stage OFF, Stage 1, Stage 2, .....		R
MV 221	LP-02-ST	State of control loop: Disabled, Heating, Cooling		R
AV 221	LP-02-SSP	Saved setpoint	16bytes	R/W
AV 222	LP-02-CSP	Calculated setpoint		R
AV 223	LP-02-PROP	Proportional output		R
MV 222	LP-02-DO	Binary output: Stage OFF, Stage 1, Stage 2, .....		R
MV 231	LP-03-ST	State of control loop: Disabled, Heating, Cooling		R
AV 231	LP-03-SSP	Saved setpoint	16bytes	R/W
AV 232	LP-03-CSP	Calculated setpoint		R
AV 233	LP-03-PROP	Proportional output		R
MV 232	LP-03-DO	Binary output: Stage OFF, Stage 1, Stage 2, .....		R
MV 241	LP-04-ST	State of control loop: Disabled, Heating, Cooling		R
AV 241	LP-04-SSP	Saved setpoint	16bytes	R/W
AV 242	LP-04-CSP	Calculated setpoint		R
AV 243	LP-04-PROP	Proportional output		R
MV 242	LP-04-DO	Binary output: Stage OFF, Stage 1, Stage 2, .....		R

### Analog Outputs

Object	Name	Description	Description	R/W
MV 311	AO-01-ST	Analog Output 1 state		R
AV 311	AO-01-VAL	Analog Output 1 Value	16bytes	R
AV 312	AO-01-OV	Analog Output 1 Override Value		R/W
MV 321	AO-02-ST	Analog Output 2 state		R
AV 321	AO-02-VAL	Analog Output 2 Value	16bytes	R
AV 322	AO-02-OV	Analog Output 2 Override Value		R/W
MV 331	AO-03-ST	Analog Output 3 state		R
AV 331	AO-03-VAL	Analog Output 3 Value	16bytes	R
AV 332	AO-03-OV	Analog Output 3 Override Value		R/W

### Digital Outputs in fan configuration

Object	Name	Description	Description	R/W
MV 412	DO-01-FAN	Binary Output 1 in fan mode: Fan Off, Fan Low, Fan Medium, Fan High	16 bytes	R
MV 413	DO-01-FAN-OV	Binary Output 1 override value		R/W
BV 511	DO-01-ALA	Fan feedback alarm		R
MV 411	DO-01-ST	Current State for Binary Output 1 – NORMAL/OVERRIDE		R
MV 442	DO-04-FAN	Binary Output 4 in fan mode: Fan Off, Fan Low, Fan Medium, Fan High	16 bytes	R
MV 443	DO-04-FAN-OV	Binary Output 4 override value		R/W
BV 541	DO-04-ALA	Fan feedback alarm		R
MV 441	DO-04-ST	Current State for Binary Output 4 – NORMAL/OVERRIDE		R

### Digital Outputs in 3-point floating configuration

Object	Name	Description	Description	R/W
AV 411	DO-01-FLT	Binary Output 1 in analog mode – FLOATING	16bytes	R
AV 412	DO-01-FLT-OV	Binary Output 1 override value		R/W
MV 411	DO-01-ST	Current State for Binary Output 1 – NORMAL/OVERRIDE		R
AV 431	DO-03-FLT	Binary Output 3 in analog mode – FLOATING	16bytes	R
AV 432	DO-03-FLT-OV	Binary Output 3 override value		R/W
MV 431	DO-03-ST	Current State for Binary Output 3 – NORMAL/OVERRIDE		R
AV 451	DO-05-FLT	Binary Output 5 in analog mode – FLOATING	16bytes	R
AV 452	DO-05-FLT-OV	Binary Output 5 override value		R/W
MV 451	DO-05-ST	Current State for Binary Output 5 – NORMAL/OVERRIDE		R

### Digital Outputs in PWM configuration

Object	Name	Description	Description	R/W
AV 413	DO-01-PWM	Binary Output 1 in analog mode PWM	16bytes	R
AV 414	DO-01-PWM-OV	Binary Output 1 override value		R/W
MV 411	DO-01-ST	Current State for Binary Output 1 – NORMAL/OVERRIDE		R
AV 423	DO-02-PWM	Binary Output 2 in analog mode PWM	16bytes	R/W
AV 424	DO-02-PWM-OV	Binary Output 2 override value		R/W
MV 421	DO-02-ST	Current State for Binary Output 2 – NORMAL/OVERRIDE		R
AV 433	DO-03-PWM	Binary Output 3 in analog mode PWM	16bytes	R
AV 434	DO-03-PWM-OV	Binary Output 3 override value		R/W
MV 431	DO-03-ST	Current State for Binary Output 3 – NORMAL/OVERRIDE		R
AV 443	DO-04-PWM	Binary Output 4 in analog mode PWM	16bytes	R
AV 444	DO-04-PWM-OV	Binary Output 4 override value		R/W
MV 441	DO-04-ST	Current State for Binary Output 4 – NORMAL/OVERRIDE		R
AV 453	DO-05-PWM	Binary Output 5 in analog mode PWM	16bytes	R
AV 454	DO-05-PWM-OV	Binary Output 5 override value		R/W
MV 451	DO-05-ST	Current State for Binary Output 5 – NORMAL/OVERRIDE		R
AV 463	DO-06-PWM	Binary Output 6 in analog mode PWM	16bytes	R
AV 464	DO-06-PWM-OV	Binary Output 6 override value		R/W
MV 461	DO-06-ST	Current State for Binary Output 6 – NORMAL/OVERRIDE		R

### Digital Outputs in binary configuration

Object	Name	Description	Description	R/W
BV 411	DO-01-BIN	Binary Output 1 in binary mode	16bytes	R
BV 412	DO-01-BIN-OV	Binary Output 1 override value		R/W
AV 511	DO-01-RT	Run time totalizer		R
BV 511	DO-01-ALA	Run time limit exceeded		R
MV 411	DO-01-ST	Current State for Binary Output 1 – NORMAL/OVERRIDE		R
BV 421	DO-02-BIN	Binary Output 2 in binary mode	16bytes	R
BV 422	DO-02-BIN-OV	Binary Output 2 override value		R/W
AV 521	DO-02-RT	Run time totalizer		R
BV 521	DO-02-ALA	Run time limit exceeded		R
MV 421	DO-02-ST	Current State for Binary Output 2 – NORMAL/OVERRIDE		R
BV 431	DO-03-BIN	Binary Output 3 in binary mode	16bytes	R
BV 432	DO-03-BIN-OV	Binary Output 3 override value		R/W
AV 531	DO-03-RT	Run time totalizer		R
BV 531	DO-03-ALA	Run time limit exceeded		R
MV 431	DO-03-ST	Current State for Binary Output 3 – NORMAL/OVERRIDE		R
BV 441	DO-04-BIN	Binary Output 4 in binary mode	16bytes	R
BV 442	DO-04-BIN-OV	Binary Output 4 override value		R/W
AV 541	DO-04-RT	Run time totalizer		R
BV 541	DO-04-ALA	Run time limit exceeded		R
MV 441	DO-04-ST	Current State for Binary Output 4 – NORMAL/OVERRIDE		R
BV 451	DO-05-BIN	Binary Output 5 in binary mode	16bytes	R
BV 452	DO-05-BIN-OV	Binary Output 5 override value		R/W
AV 551	DO-05-RT	Run time totalizer		R
BV 551	DO-05-ALA	Run time limit exceeded		R
MV 451	DO-05-ST	Current State for Binary Output 5 – NORMAL/OVERRIDE		R
BV 461	DO-06-BIN	Binary Output 6 in binary mode	16bytes	R
BV 462	DO-06-BIN-OV	Binary Output 6 override value		R/W
AV 561	DO-06-RT	Run time totalizer		R
BV 561	DO-06-ALA	Run time limit exceeded		R
MV 461	DO-06-ST	Current State for Binary Output 6 – NORMAL/OVERRIDE		R



## Remotely changing the configuration of the controller

Object	Name (8 Bytes)	Description / Property description	Range/Type	R/W
AV 12	ParAdd	Address of parameter, see table below	AV	R/W
AV 13	ParValue	Parameter value, use table below	AV	R/W

With the addresses listed in the table below the settings may be changed of the controller. They correspond with the parameter settings for the addressed TCX2 controller.

The address is calculated by adding the parameter number to the value from the table below. To use the table, choose the type of parameter by selecting the row of the table and then choose the item with the column. UI5 would result in 3400. Parameter 5U10 would thus be address 3410.

Enter the address into ParAdd AV12 value. AV12 works like as address pointer.  
 Read or write the contents of the value in AV13. AV13 works like an indirect reference register.

Description	1	2	3	4	5	6	7	8	9	10	11	12
User settings	2000											
Universal input	3000	3100	3200	3300	3400	3500	3600	3700	3800	3900		
Control Loop	5000	5100	5200	5300								
Analog Output	6000	6100	6200									
Binary Output	7000	7100	7200	7300	7400	7500						
Fan output	8000	8100										
Alarm	9000	9100	9200	9300	9400	9500	9600	9700				
Functions	10000	10100	10200	10300	10400							
Time Schedules	11100	11200	11300	11400	11500	11600	11700	11800	11900	12000	12100	12200
Communication	13000											

### Time schedule Settings

Time schedules are slightly special as they do not operate with parameters. Time Schedules addresses start at address 11000. To remotely change time schedule settings, follow the table below.

Address	Module	Description	Range	R/W
11000	General	Enable time schedules	1bit	R/W
Table+0	SCHED1	Time of time schedule event	time	R/W
Table+1	SCHED1	Active days of time schedule event (bits) Bit 0 = Day 1 (Monday) Bit 1 = Day 2 (Tuesday) Bit 2 = Day 3 (Wednesday) Bit 3 = Day 4 (Thursday) Bit 4 = Day 5 (Friday) Bit 5 = Day 6 (Saturday) Bit 6 = Day 7 (Sunday)	8bit	R/W
Table+2	SCHED1	Type of time schedule: 0 = Disabled 1 = Operation mode 2 = Control loop setpoint 3 = Analog output setpoint 4 = Fan output 5 = Binary output	8bit	R/W
Table+3	SCHED1	ID of time schedule: Will show only if type of schedule is not operation mode.	8bit	R/W
Table+4	SCHED1	Type of times schedule is operation mode: 0 = OFF, 1 = Economy, 2 = ON For all other types: Setpoint	8bit	R/W